



# TORUS POWER

Engineered to perform  
& protect like no other

Toroidal Isolation  
Power Transformers

## WM Series Manual

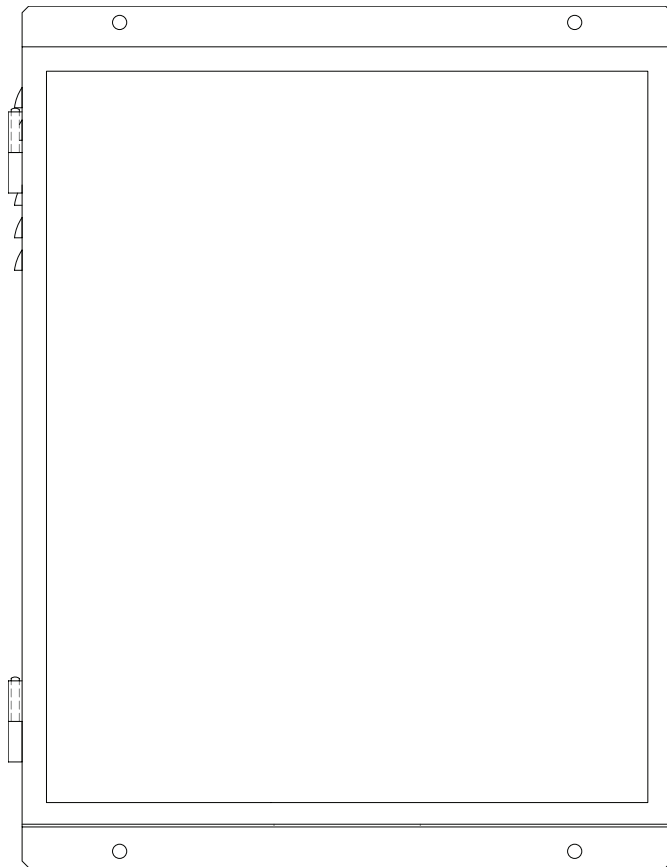

**Warning:**

User is responsible for installing this unit in accordance with all local, provincial/state and federal electrical code requirements. The installation of this unit requires inspection and approval by local safety authority. This wall mount unit is not equipped with a power safety interlock.



## Table of Contents

---

Table of Contents.....	Page 1
Important Safety Instructions.....	Page 2
Shipping Carton & Packing Material.....	Page 2
Placement & Ventilation.....	Page 2
Torus Power WM Series Description.....	Page 3
Transient Voltage Surge Suppression (TVSS).....	Page 3
Power Sharing Outputs.....	Page 3
Circuit Protection.....	Page 3
Thermal Protection.....	Page 3
Circuit Schematic - North American WM Model.....	Page 4
Layout - North American WM Model.....	Page 5
Electrical Specifications - North American Models.....	Page 6
Electrical Specifications - International Models.....	Page 6
Mechanical Specifications - North American Models.....	Page 6
Mechanical Specifications - International Models.....	Page 6
Wall Cabinet External Layout - WM Series.....	Page 7
Warranty.....	Page 8

## Important Safety Instructions

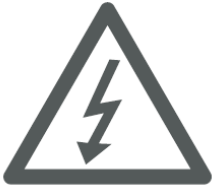

**CAUTION!** To reduce the risk of electric shock and fire, do not remove the cover of this device. There are no user serviceable parts inside. Please refer all servicing to licensed service technicians.

**CAUTION!** The international symbol of a lightning bolt inside a triangle is intended to alert the user to uninsulated "dangerous voltage" within the device's enclosure. The international symbol of an exclamation point inside a triangle is intended to alert the user to the presence of important operating, maintenance and servicing information in the manual accompanying the device.



**CAUTION!** To prevent electrical shock, match wide blade of plug to wide slot, fully insert.

**CAUTION!** To reduce the risk of electrical shock, do not expose this equipment to rain or moisture.

1. Read Instructions—All safety and operating instructions should be read before operating the device.
2. Retain Instructions—The safety and operating instructions should be retained for future reference.
3. Heed Warnings—All warnings on the device and in the operating instructions should be adhered to.
4. Follow Instructions—All operating and safety instructions should be followed.
5. Water & Moisture—The device should never be used in, on or near water for risk of fatal shock.
6. Ventilation—The device should always be located in such a way that it maintains proper ventilation. It should never be placed in a built-in installation or anywhere that may impede the flow of air through its ventilation slots.
7. Heat—Never locate the device near heat sources such as radiators, floor registers, stoves or other heat-generating devices.
8. Power Cord Protection—Power cables should be routed so they are not likely to be stepped on or crushed by items placed on them or against them. Special attention should be paid to areas where the plug enters a socket or fused strip and where the cord exits the device.
9. Periods Of Non-Use—The device should be unplugged when not being used for extended periods.
10. Dangerous Entry—Care should be taken that no foreign objects or liquids fall or are spilled inside the device.
11. Service—The device should always be serviced by licensed technicians. Only replacement parts specified by the manufacturer should be used. The use of unauthorized substitutions may result in fire, shock, or other hazards.
12. Damage Requiring Service—The device should be serviced by licensed technicians when:
  - The plug or power supply cord has been damaged.
  - Objects have fallen or liquid has spilled inside the device.
  - The device has been exposed to moisture.
  - The device does not appear to be operating properly or exhibits a marked change in performance.
  - The device has been dropped or the enclosure becomes damaged.
13. Do not position the equipment so that it is difficult to operate the disconnecting device (power cord).
14. If the equipment is used in a manner not specified by the manufacturer, the protection provided by the equipment may be impaired.
15. The power switch should be in the "off" position when connecting or disconnecting equipment from a Torus Power unit.
16. CAUTION Some units can be very heavy, please use safe practices when lifting.



≥18 kg (39.7 lb)



≥32 kg (70.5 lb)



≥55 kg (121.2 lb)

## Shipping Carton & Packing Material

Please keep the original shipping box and all packing material. This will ensure the unit is protected in future transport.

In the unlikely event you have a problem and must return it for service you must use the original packing material.

Ship the unit only in the original packing material, as the unit is not insurable by carriers otherwise.

## Placement & Ventilation

Torus power PIUs (Power Isolation Units) are extremely efficient yet very high power devices, and must be adequately cooled.

Wall Mount units have ventilation slots on the side panels near the top of the unit. Maintain at least 5" distance from each of these surfaces to anything else.

Do not install the unit directly above heat generating equipment.

## Torus Power WM Series Description

---

Torus Power PIUs (Power Isolation Units) combine the best surge suppression with unique toroidal transformer technologies from PLITRON to provide the ultimate performance and protection for sensitive audio and video equipment applications.

Balanced input power from two 120V phases provides high input power and noise cancellation. Using balanced input power provides the benefits of symmetrical power without the requirement to use GFCI (ground fault circuit interruption) outlets. GFCIs are prone to nuisance trips. The toroidal isolation transformer steps down the 240V input to 120V to power equipment. (Where 240V balanced input is unavailable, units may be configured for 208V operation.)

PIUs use ZeroSurge patented series-mode surge removal filters to absorb dangerous voltage surges and safely dissipate them without using failure prone MOVs (metal oxide varistors). Also, unlike MOV based protection, voltage surges are not shunted to ground.

Isolation is combined with proven proprietary technologies from PLITRON in the oversized toroidal transformer. NBT works as a low pass filter using the controlled leakage inductance and capacitances within the transformer to cancel common mode and differential mode noise. LoNo technology has been used for years by high end audio companies who demand silent transformers. Imin technology reduces inrush currents. UST provides additional common mode filtering using a highly efficient Faraday screen.

Low-impedance output with balanced high power primary input provides the most unconstrained, yet protected, energy source available to your equipment.

## Transient Voltage Surge Suppression (TVSS)

---

All WM Series models are available with a Transient Voltage Surge Suppression (TVSS) device built into its signal path. The UL certified panel TVSS responds in under 5 nano-seconds and manages surges up to 80,000 Amps. The TVSS also offers additional noise filtration of EMI and RFI (40 dB typical).

## Power Sharing Outputs

---

Each output circuit breaker protects an individual circuit. However, all circuits share a single winding (output) on the isolation transformer. This "Power-Sharing" allows huge excursions of current, up to and beyond the full power of the unit, to be available at any individual circuit, for instantaneous bursts of power.

## Circuit Protection

---

The input fuses prevent excessive current from entering the PIU.

## Thermal Protection

---

The Torus Power PIU will shut down if internal unit temperature reached excessive levels.

# Circuit Schematic - North American WM Model (WM 45 BAL TVSS)

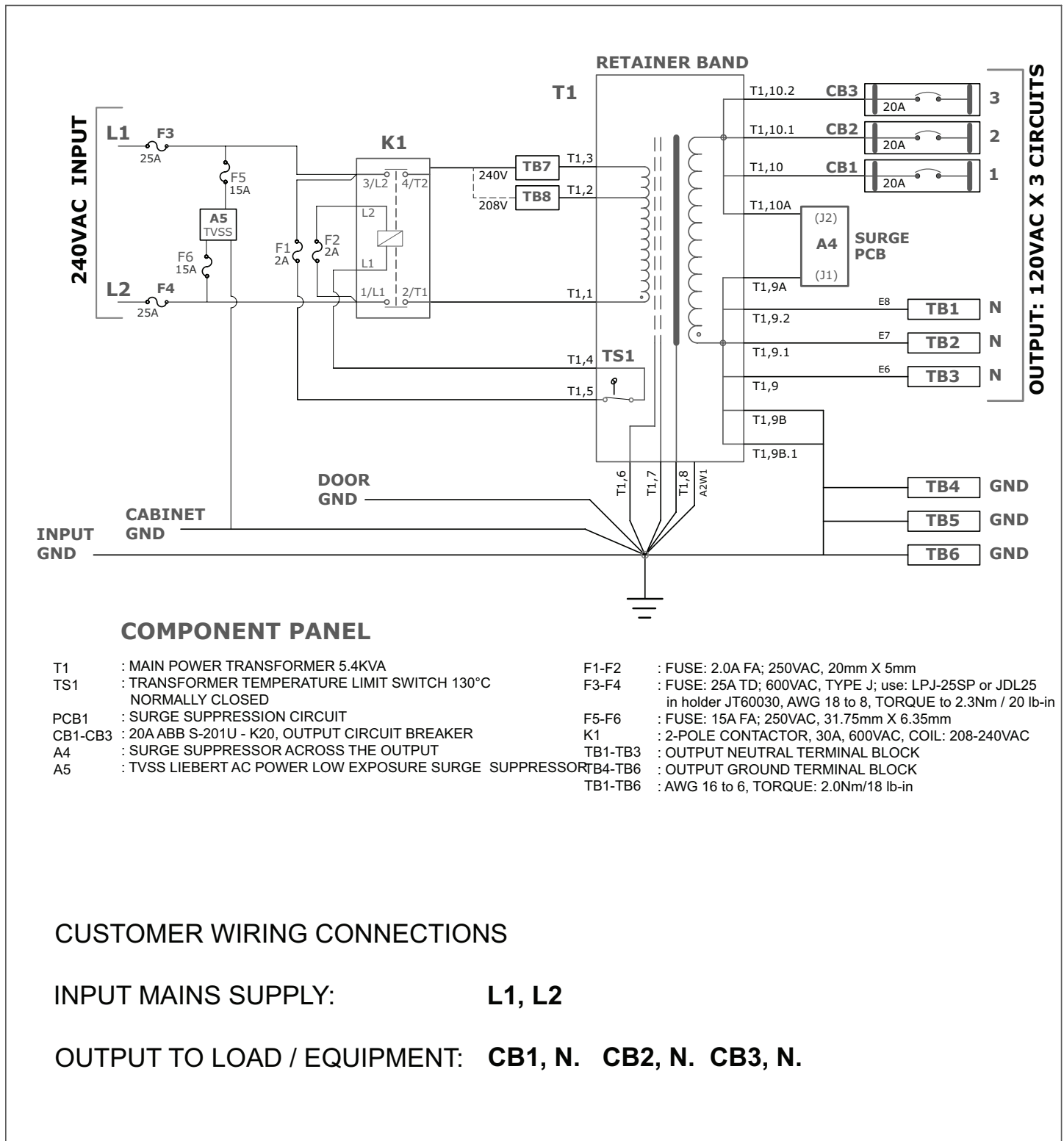

**Note:**

Circuit schematic drawing is provided for reference only, Torus Power WM units have no user serviceable parts inside. Please return unit to manufacturer for repair and service when required.

# Layout - North American WM Model (WM 45 BAL TVSS)

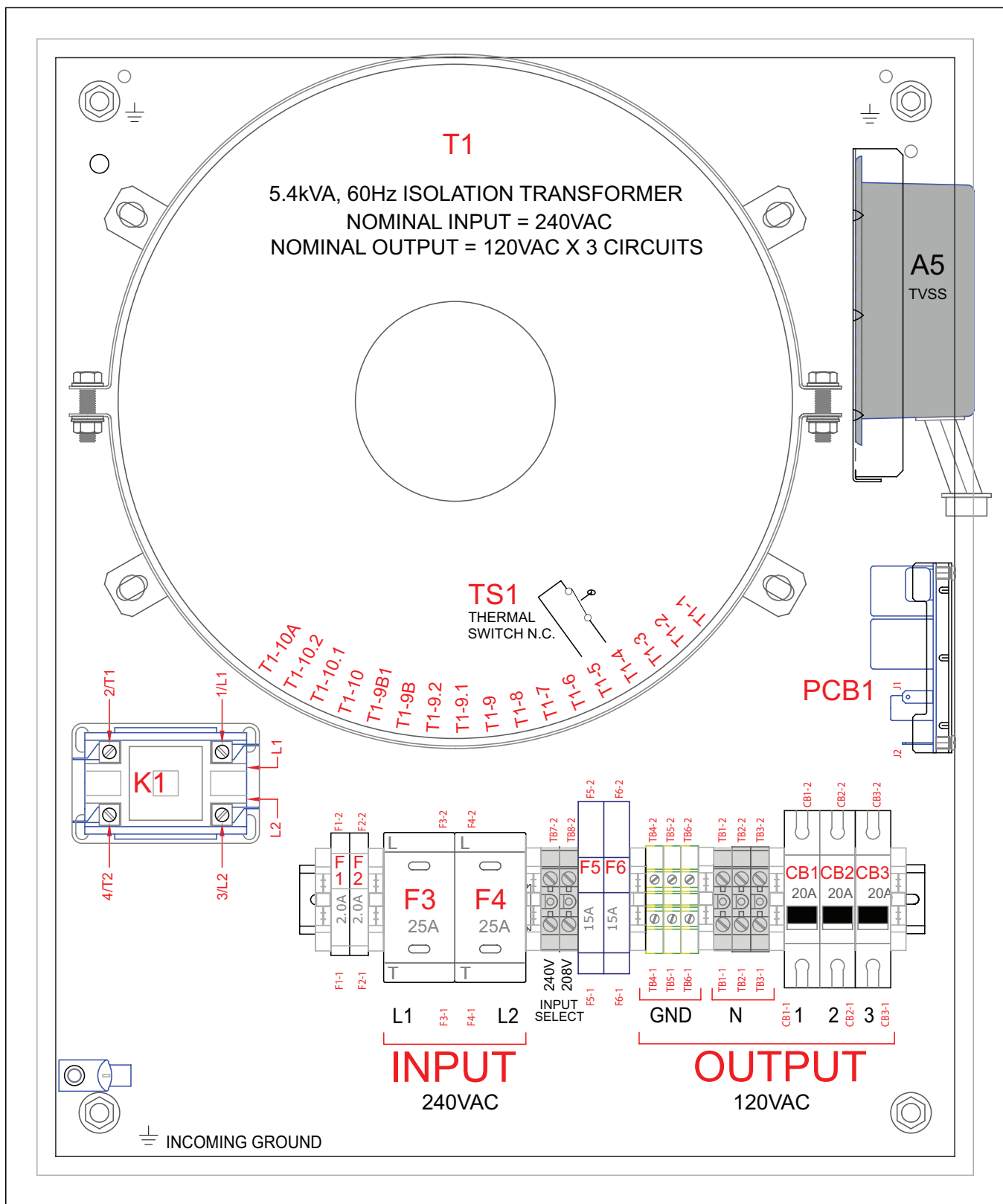

**Note:**

Layout drawing is provided for reference only, Torus Power WM units have no user serviceable parts inside. Please return unit to manufacturer for repair and service when required.

## Electrical Specifications - North American Model

Model Number	Input Voltage Nominal	Output Voltage Nominal	Surge Suppression	Input Current Limiting	Output Circuit Breakers	Maximum Available Output Current
WM 45 BAL	240VAC, 60Hz or 208VAC, 60HZ	120VAC	NO	2x25A (Fuses)	3x20A	45A
WM 60 BAL				2x30A (Fuses)	3x20A	60A
WM 75 BAL				2x40A (Fuses)	5x20A	75A
WM 100 BAL				2x50A (Fuses)	5x20A	100A
WM 45 BAL TVSS	240VAC, 60Hz or 208VAC, 60HZ	120VAC	YES	2x25A (Fuses)	3x20A	45A
WM 60 BAL TVSS				2x30A (Fuses)	3x20A	60A
WM 75 BAL TVSS				2x40A (Fuses)	5x20A	75A
WM 100 BAL TVSS				2x50A (Fuses)	5x20A	100A

## Electrical Specifications - International Model

Model Number	Input Voltage Nominal	Output Voltage Nominal	Surge Suppression	Input Current Limiting	Output Circuit Breakers	Maximum Available Output Current
WM 30	220-240VAC, 50/60Hz	220-240VAC	NO	2x30A (Fuses)	3x15A	30A
WM 45				2x45A (Fuses)	5x15A	45A
WM 30 TVSS	220-240VAC, 50/60Hz	220-240VAC	YES	2x30A (Fuses)	3x15A	30A
WM 45 TVSS				2x45A (Fuses)	5x15A	45A

## Mechanical Specifications - North American Model

Model Number	Weight KG(lb)	Size, mm (HxWxD) Size, inch (HxWxD)	Construction
WM 45 BAL	74.5 (164)	673x526x261 26.5x20.7x10.3	NEMA TYPE 1 Enclosure 14 guage steel Black Powder Coat Slip hinges enable door removal 1/4 turn latch
WM 60 BAL	86.5 (191)		
WM 75 BAL	99.5 (219)		
WM 90 BAL	105.5 (233)		
WM 45 BAL TVSS	76 (168)	673x526x261 26.5x20.7x10.3	
WM 60 BAL TVSS	88 (194)		
WM 75 BAL TVSS	101 (223)		
WM 90 BAL TVSS	107 (236)		

## Mechanical Specifications - International Model

Model Number	Weight KG(lb)	Size, mm (HxWxD) Size, inch (HxWxD)	Construction
WM 30	89.5 (197)	673x526x261 26.5x20.7x10.3	NEMA TYPE 1 Enclosure 14 guage steel Black Powder Coat Slip hinges enable door removal 1/4 turn latch
WM 45	105.5 (233)		
WM 30 TVSS	91 (201)	673x526x261 26.5x20.7x10.3	
WM 45 TVSS	107 (236)		



# Wall Cabinet External Layout - WM AVR Series

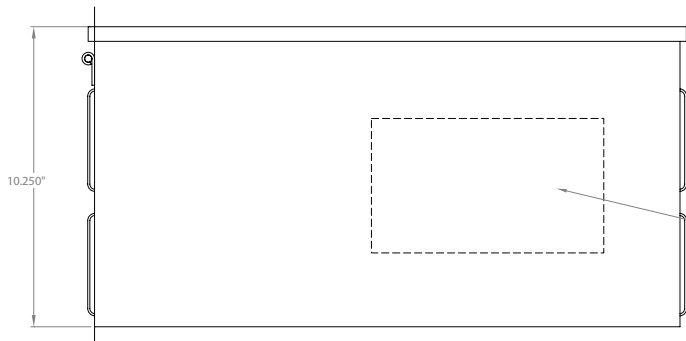
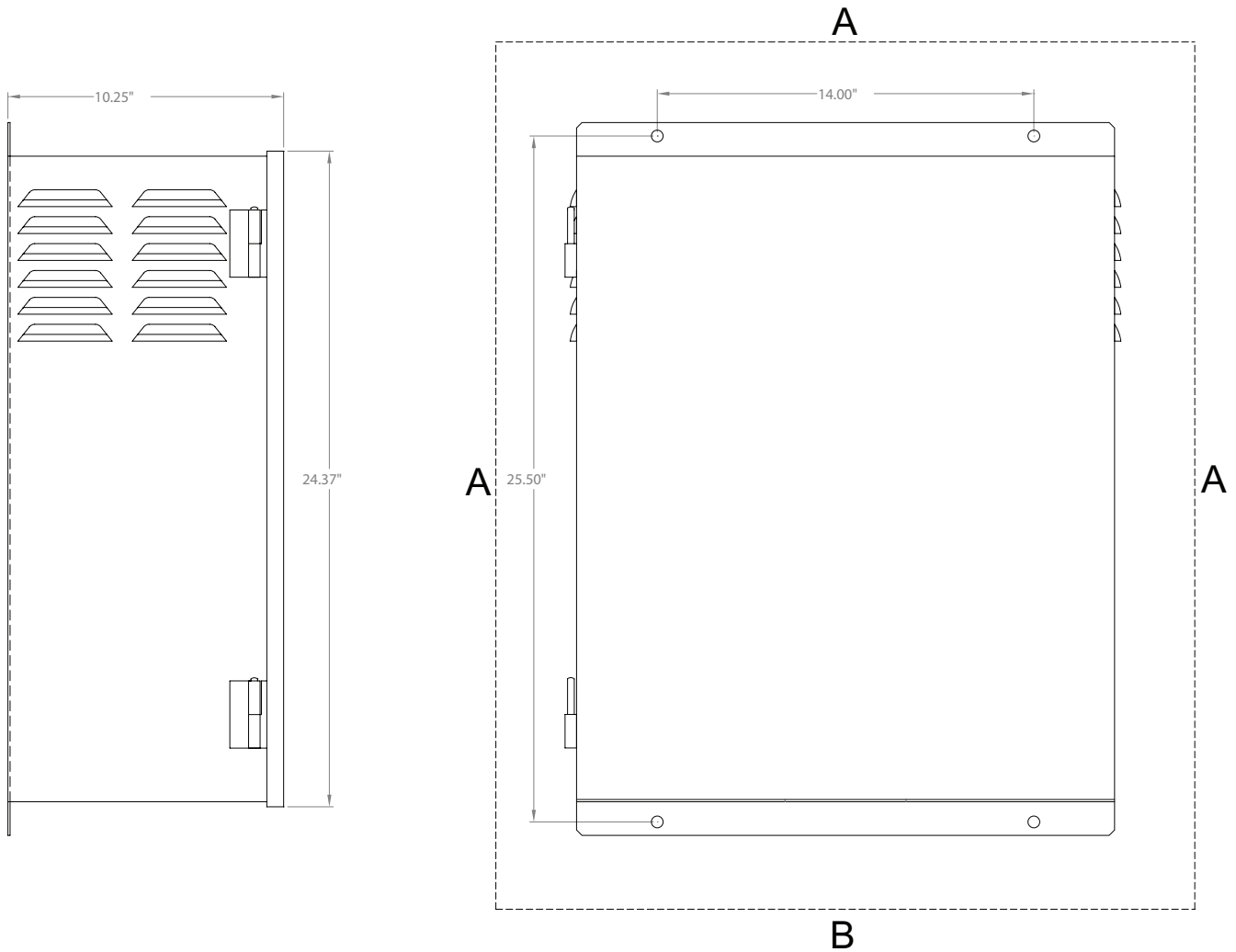

Space around unit as shown above:  
'A' = 5.00"  
'B' = 6.00"

Customer electrical connections:  
Wiring conduit holes should be added as required to this area.

## Warranty

---

Torus Power Inc. products are warranted to be free from manufacturing defects as follows:

- Five years from the original date of sale for toroidal transformers
- Two years from the original date of sale for all other components

The product warranty includes parts, labour and return shipping to the customer. Shipping to Torus Power Inc. for warranty repair is the responsibility of the customer.

Warranty coverage is not transferrable and original proof of purchase is required for warranty claims.

In the event of a warranty claim, Torus Power Inc. will remedy the issue by repair or replacement, as we deem necessary, to restore the product to full performance.

This warranty is considered void if the failure of the product or any component part is caused by damage or misuse.

Failure to fully comply with Torus Power operating instructions voids the warranty.



Torus Power products are marketed worldwide by Torus Power Inc.

**For sales contact:**

[sales@toruspower.com](mailto:sales@toruspower.com)

Phone: (+1) 416-477-4799

Toll free: 1-877-337-9480

**Technical inquiries:**

[tech@toruspower.com](mailto:tech@toruspower.com)

Phone: (+1) 416-477-4799

Toll free: 1-877-337-9480



# TORUS POWER

Engineered to perform  
& protect like no other

**Toroidal Isolation  
Power Transformers**

**Torus Power Inc.**

2861 Sherwood Heights Drive

Suite 26

Oakville, ON L6J 7K1

[www.toruspower.com](http://www.toruspower.com)