



TORUS POWER

Engineered to perform
& protect like no other

Toroidal Isolation
Power Transformers

WM AVR Series Manual

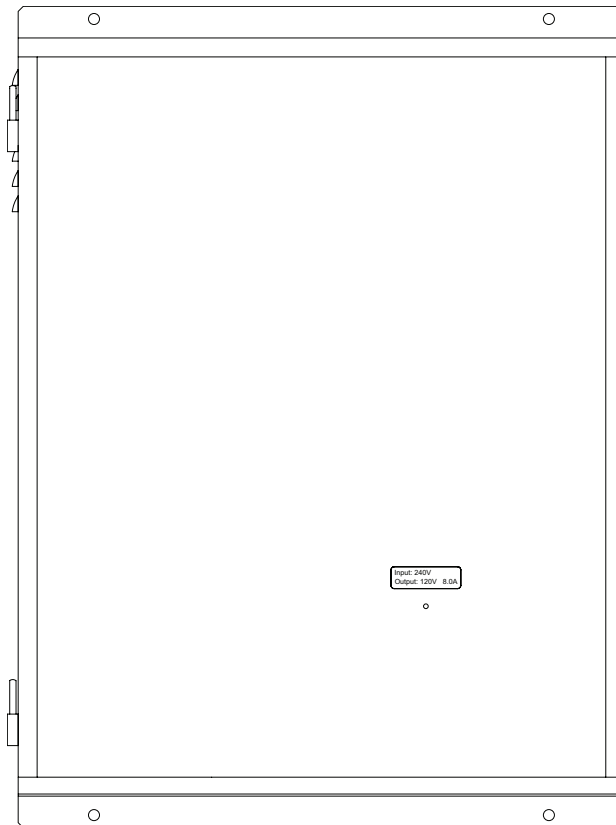

Warning:

User is responsible for installing this unit in accordance with all local, provincial/state and federal electrical code requirements. The installation of this unit requires inspection and approval by local safety authority. This wall mount unit is not equipped with a power safety interlock.

Table of Contents

Table of Contents.....	Page 1
Important Safety Instructions.....	Page 2
Shipping Carton & Packing Material.....	Page 2
Placement & Ventilation.....	Page 2
Torus Power AVR Description.....	Page 3
Front Panel Display.....	Page 4
Ethernet Connections and AVR Software.....	Page 5
AVR Software - Menu Selection.....	Page 6,7,8
Block Diagram - AVR System.....	Page 9
Transient Voltage Surge Suppression (TVSS).....	Page 9
Circuit Protection.....	Page 9
Thermal Protection.....	Page 9
Circuit Schematic - North American WM AVR Model.....	Page 10
Layout - North American WM AVR Model.....	Page 11
Electrical Specifications - North American Models.....	Page 12
Electrical Specifications - International Models.....	Page 12
Mechanical Specifications - North American Models.....	Page 12
Mechanical Specifications - International Models.....	Page 12
Wall Cabinet External Layout - WM AVR Series.....	Page 13
Home Automation Interface.....	Page 14
Warranty.....	Page 14

Important Safety Instructions



CAUTION! To reduce the risk of electric shock and fire, do not remove the cover of this device. There are no user serviceable parts inside. Please refer all servicing to licensed service technicians.

CAUTION! The international symbol of a lightning bolt inside a triangle is intended to alert the user to uninsulated "dangerous voltage" within the device's enclosure. The international symbol of an exclamation point inside a triangle is intended to alert the user to the presence of important operating, maintenance and servicing information in the manual accompanying the device.



CAUTION! To prevent electrical shock, match wide blade of plug to wide slot, fully insert.

CAUTION! To reduce the risk of electrical shock, do not expose this equipment to rain or moisture.

1. Read Instructions—All safety and operating instructions should be read before operating the device.
2. Retain Instructions—The safety and operating instructions should be retained for future reference.
3. Heed Warnings—All warnings on the device and in the operating instructions should be adhered to.
4. Follow Instructions—All operating and safety instructions should be followed.
5. Water & Moisture—The device should never be used in, on or near water for risk of fatal shock.
6. Ventilation—The device should always be located in such a way that it maintains proper ventilation. It should never be placed in a built-in installation or anywhere that may impede the flow of air through its ventilation slots.
7. Heat—Never locate the device near heat sources such as radiators, floor registers, stoves or other heat-generating devices.
8. Power Cord Protection—Power cables should be routed so they are not likely to be stepped on or crushed by items placed on them or against them. Special attention should be paid to areas where the plug enters a socket or fused strip and where the cord exits the device.
9. Periods Of Non-Use—The device should be unplugged when not being used for extended periods.
10. Dangerous Entry—Care should be taken that no foreign objects or liquids fall or are spilled inside the device.
11. Service—The device should always be serviced by licensed technicians. Only replacement parts specified by the manufacturer should be used. The use of unauthorized substitutions may result in fire, shock, or other hazards.
12. Damage Requiring Service—The device should be serviced by licensed technicians when:
 - The plug or power supply cord has been damaged.
 - Objects have fallen or liquid has spilled inside the device.
 - The device has been exposed to moisture.
 - The device does not appear to be operating properly or exhibits a marked change in performance.
 - The device has been dropped or the enclosure becomes damaged.
13. Do not position the equipment so that it is difficult to operate the disconnecting device (power cord).
14. If the equipment is used in a manner not specified by the manufacturer, the protection provided by the equipment may be impaired.
15. The power switch should be in the "off" position when connecting or disconnecting equipment from a Torus Power unit.
16. CAUTION Some units can be very heavy, please use safe practices when lifting.



≥18 kg (39.7 lb)



≥32 kg (70.5 lb)



≥55 kg (121.2 lb)

Shipping Carton & Packing Material

Please keep the original shipping box and all packing material. This will ensure the unit is protected in future transport.

In the unlikely event you have a problem and must return it for service you must use the original packing material.

Ship the unit only in the original packing material, as the unit is not insurable by carriers otherwise.

Placement & Ventilation

Torus power PIUs (Power Isolation Units) are extremely efficient yet very high power devices, and must be adequately cooled.

Wall Mount units have ventilation slots on the side panels near the top of the unit. Maintain at least 5" distance from each of these surfaces to anything else.

Do not install the unit directly above heat generating equipment.

Torus Power AVR Description

Torus Power AVR – Description

The Torus Power AVR (Automatic Voltage Regulation) is a full-feature state-of-the-art power transformer, isolating and protecting your system. Like all Torus Power products, the AVR series provides true isolation (using massive toroidal transformers) and protects all connected equipment from the risk of severe power line surges using series-mode surge suppression. In addition, Torus AVR provides stable voltage to keep equipment running in the optimal range of 115VAC to 125VAC for any input voltage from 170V to 270VAC. (International units operate within nominal input voltage such as 220V, 230V, 240V; Torus AVR keeps them operating within a range of +/- 10V.) See table on Page 9 for more details.

The Torus Power AVR series uses a micro-processor to monitor and control the power provided to connected components. The front panel display on the Torus Power AVR indicates input and output voltages, and displays output current, as well as displaying fault conditions.

The Torus Power AVR is pre-programmed to power down the system when a high or low fault conditions occurs (user can over-ride).

There are multiple interfaces built into the Torus Power AVR:

- 1) Ethernet interface with built-in web server allows any computer to view voltage and current readings and turn the AVR unit ON or OFF.
- 2) RS-232 is provided for connection to media control systems.
- 3) Two 12VDC triggers are provided.

Using the AVR

While the AVR has built-in software that can be accessed via the Ethernet connection, there is no need for you to use this software. The AVR system provides all the standard features, performance, and benefits out - of - the - box by simply plugging it in as described in this section. You can use the AVR software to monitor the voltage conditions via your computer, and for such additional features as being able to turn your system on/off remotely and change the duration of the display's backlight.

Does your system need automatic voltage regulation?

Under ideal conditions, when the supplied power line is stable and dependable, you may not need voltage regulation. In such an ideal situation, your equipment can operate within the normal tolerance of the line voltage.

In reality, the power supplied to most areas is less than ideal due to outdated power grids. In most areas, the power regularly drops or rises beyond the acceptable range (in North America +/- 5V, Europe/Asia/Australia +/- 10V) . These voltage sags, brownouts, and surges can stress components and shorten equipment life. In the worst case, catastrophic events can destroy valuable equipment. In such real-world conditions, the Torus Power AVR can protect your equipment, and improve the quality and enjoyment of your audio and video experience.

Front Panel Display

Front Panel

The front panel display consists of a 2 line LCD and 1 push button.

Typical Display

In: 115V
Out: 120V 5.2A

Press button to show IP address (if Internet connection is used).

IP Address
10.1.1.112

See section on AVR software for further information on the IP address.

Voltage Faults

If a high or low voltage condition exists for 30 seconds or more, a voltage fault is displayed and the system shuts down (unless over-ridden by the user).

Display will Show

System OFF
LOW AC VOLTAGE

or

System OFF
HIGH AC VOLTAGE

As the output power from the Torus Power AVR is shut down, all the connected components are turned off. The AVR power switch remains in the ON position, although there is no power to the load.

The connected equipment should be switched off.

When the voltage has been restored to the normal operating range, the following procedure can be followed:

- The Torus Power AVR can be switched OFF and then ON.
- Wait thirty seconds to verify the fault condition no longer exists.
- The connected equipment should be switched ON individually.

If the fault condition still exists, the AVR will require approximately 15 seconds to monitor the incoming voltage, and the system will shut down again.

The user can program the AVR software to allow the system to remain ON, in case of fault (see AVR software section for details).

Ethernet Connections and AVR Software

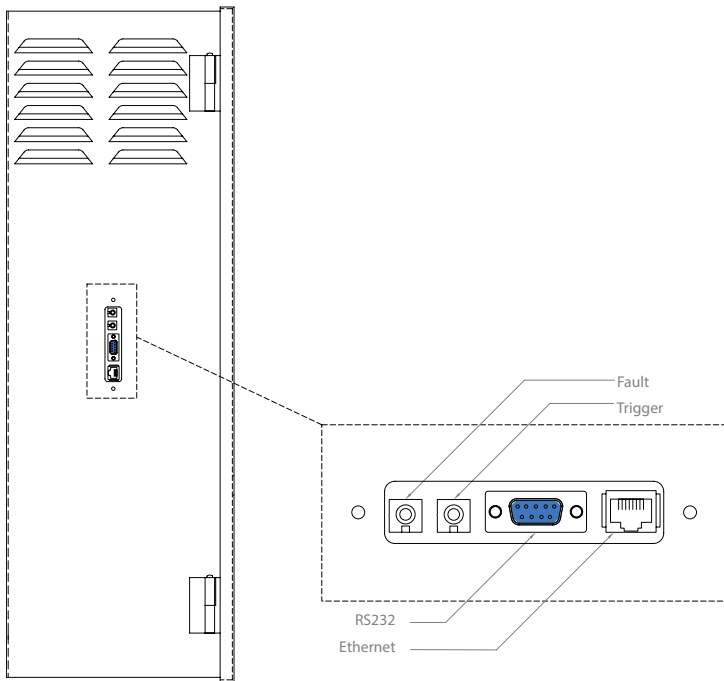

Ethernet

Allows access to the AVR and internal software. See AVR software section for more details.

RS232

Allows access to automation and external control. See Home Automation Interface commands at end of manual.

12VDC Trigger On/Off

The AVR can be turned on and off by a 12 volt trigger input. Applying 12 volts turns on the AVR and removing the 12 volts turns it off.

12VDC Fault Output

The AVR provides a 12 volt fault output through a jack on the back panel. The output goes to 12 volts when a relay or voltage fault is detected. The maximum current that can be drawn from this output is 75mA.

AVR Software

AVR software is resident in the microprocessor on the internal control board. There are two methods to access the software.

- 1) Connect the AVR to the Ethernet port. Open a browser window on a PC that is connected to the same network through another Ethernet port. Enter AVR (or the IP address displayed on the LCD) into the browser window. Press ENTER and the software will open.
- 2) Use a three way hub, which is connected to an existing network. You then connect both PC and AVR to the same hub. Open a browser window from the PC. Type AVR, (or the IP address displayed on the LCD) into the browser window. Press ENTER and the software will open.

Username and Password

The password is required to change the setup of the Torus unit.

Username is **admin** This is factory set and cannot be changed.

Password is **avr** This is the default password, and can be changed.

In case you forget your password, the AVR can be restored to the factory default password **avr** by pressing and holding the button on the front panel for at least 10 seconds.

AVR Software - Menu Selections

AVR Menu Selections

- AVR Status
- Switch Power
- Setup
- Email Configuration
- Set Password
- Torus Power Home (website)
- Network Configuration

Screen by screen description of software options

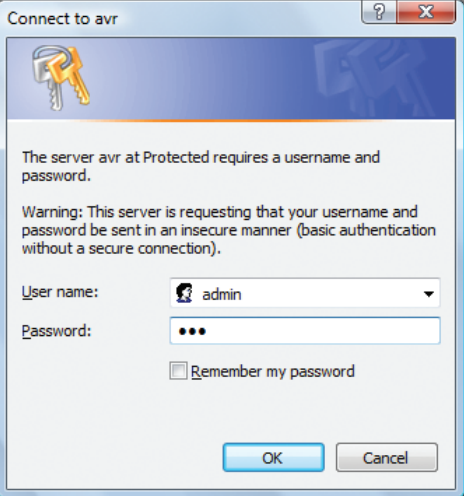
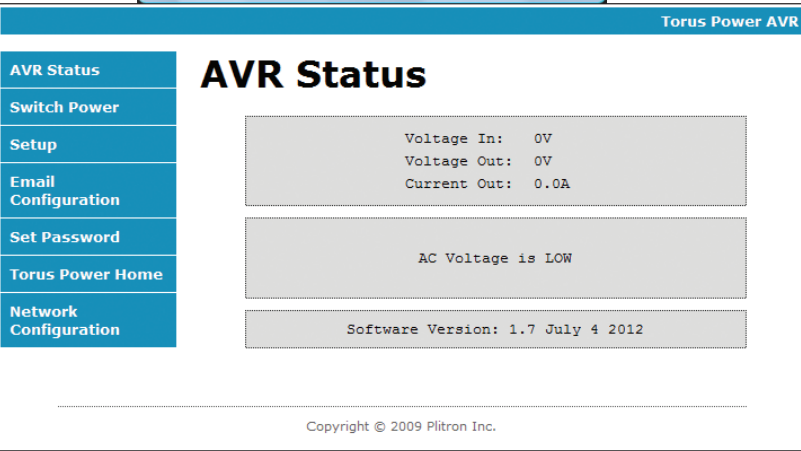
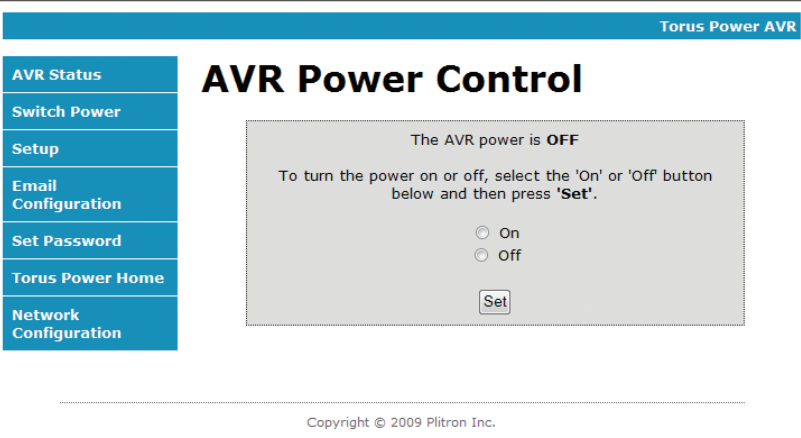
	<p>Access to AVR Software To access AVR software, enter user name and password.</p> <p>User name: admin is factory set and cannot be changed.</p> <p>Default password: avr You can change your password.</p> <p>Select: Set Password</p>
	<p>AVR Status This screen indicates the overall status of the system, showing Voltage In, Voltage Out, and Current Out.</p> <p>It also reports if the system is functioning normally or whether there is a fault condition.</p>
	<p>AVR Power Control This screen allows ON or OFF control of the AVR unit.</p> <p>Press SET button to implement your selection.</p>

AVR Software - Menu Selections (continued)

Torus Power AVR

AVR Status
Switch Power
Setup
Email Configuration
Set Password
Torus Power Home
Network Configuration

AVR Setup

This page allows the configuration of the AVR's programmable parameters.

Shutdown on Low or High line voltage

LCD Backlight Always On

LCD Backlight Time: 255 (0 to 255 seconds)

Save Setup

Copyright © 2009 Plitron Inc.

AVR Setup

This screen allows the user to configure two AVR parameters.

1. Shutdown on Low or High line voltage

The factory default is YES to shut down in case of fault conditions. Unselecting this button will override, and the AVR will remain ON even if voltage drops or rises beyond the acceptable range.

2. LCD Display.

Always ON is the default setting. If you don't want the display on all the time, you can select a time from 0 to 255 seconds. When you have made your selections, press SAVE SETUP.

Torus Power AVR

AVR Status
Switch Power
Setup
Email Configuration
Set Password
Torus Power Home
Network Configuration

Email Configuration

1. Please enter the "Email Address" that the logged data should be sent to.
2. If you have multiple AVR devices, assign different "Email Subjects" to them to tell apart the logs of different devices.

Email Configuration

SMTP Server: [] Port: 25

User Name: []

Password: []

Email Address: []

Email Subject: []

Send Test Email

Copyright © 2009 Plitron Inc.

Email Fault Alert Notification

In the unlikely event your AVR experiences an issue, the AVR will shut down and send an email notification if this section is configured. After entering the configuration parameters use the 'Send Test Email' button to confirm your settings are correct.

Torus Power AVR

AVR Status
Switch Power
Setup
Email Configuration
Set Password
Torus Power Home
Network Configuration

Set Password

Enter New Password: []

Re-enter Password: []

Save Password

Copyright © 2009 Plitron Inc.

Set Password

If you wish to change the password, use this screen.

In case your forget your new password, you can restore the AVR to factory default password by pressing the button on the front of the AVR unit and **HOLDING** it down for at least 10 seconds. The default password is **avr**.

AVR Software - Menu Selections (continued)

Torus Power AVR

- AVR Status
- Switch Power
- Setup
- Email Configuration
- Set Password
- Torus Power Home
- Network Configuration

AVR Network Configuration

This page allows the configuration of the AVR's network settings.

CAUTION: Incorrect settings may cause the AVR to lose network connectivity. Recovery options will be provided on the next page.

Enter the new settings for the AVR below:

MAC Address:	<input type="text" value="00:50:C2:B5:D1:36"/>
Host Name:	<input type="text" value="AVR"/>
	<input checked="" type="checkbox"/> Enable DHCP
IP Address:	<input type="text" value="192.168.1.100"/>
Gateway:	<input type="text" value="192.168.1.1"/>
Subnet Mask:	<input type="text" value="255.255.255.0"/>
Primary DNS:	<input type="text" value="192.168.1.1"/>
Secondary DNS:	<input type="text" value="0.0.0.0"/>
<input type="button" value="Save Config"/>	

Copyright © 2009 Plitron Inc.

Each AVR unit has a unique MAC Address which is factory assigned.

The IP address assigned to the AVR is dynamically assigned and is displayed on this screen as well as on the front panel LCD of the AVR.

The AVR can be programmed through the web browser to automatically get an IP address from the network switch or router and this is the default setting and should work on most networks. Some networks require each PC or device to use a fixed IP address and the AVR also supports this option.

Notes:

1. The output current (Amps) displayed on the LCD is the RMS reading of the load. It does not indicate the peak current loads.
2. There is a 20-second delay built into the AVR system, to prevent nuisance switching. The AVR will take approximately 20-seconds to change relay taps to switch to the proper output voltage setting.
3. North American WM BAL models: Torus AVR will keep the output constant within the range of 115Volts to 125Volts, with an input voltage of 170V to 270V. Between 160V to 170V, and between 260V and 270V, the regulation will be reduced.
4. International WM models: Torus AVR will keep the output constant within the range of 240 ± 10 Volts, with an input voltage of 170V to 270V. Between 160V to 170V, and between 260V and 270V, the regulation will be reduced.
5. A drop in the input voltage is normal when increasing the load on the Torus AVR. This is a result of the impedance of the power line, and is a function of the distance from the electrical panel.

Switch On Delay Feature

The Automatic Voltage Regulation (AVR) feature is designed to handle normal utility fluctuations to provide the connected equipment with an optimal voltage supply. It is common when utility power is restored after a blackout that the voltage supply is unstable for a few seconds. To further protect connected equipment your AVR is equipped with a start up delay feature. When the power switch is turned on or when the power switch is on and utility power is restored, power will not be connected to the output receptacles until the delay time has passed.

Block Diagram - AVR System

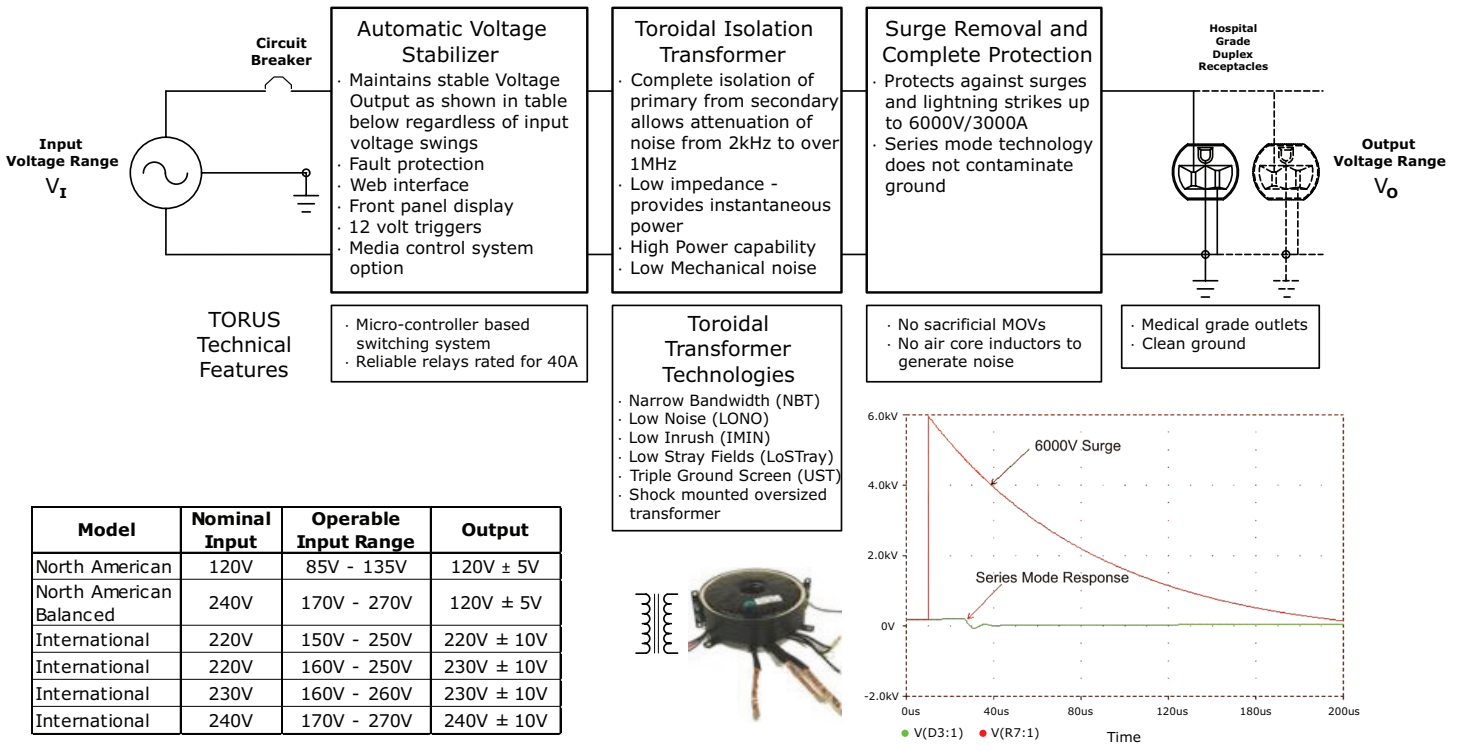

Transient Voltage Surge Suppression (TVSS)

All WM Series models are available with a Transient Voltage Surge Suppression (TVSS) device built into its signal path. The UL certified panel TVSS responds in under 5 nano-seconds and manages surges up to 80,000 Amps. The TVSS also offers additional noise filtration of EMI and RFI (40 dB typical).

Circuit Protection

The input fuses prevent excessive current from entering the PIU.

Thermal Protection

The Torus Power PIU will shut down if internal unit temperature reached excessive levels.

Circuit Schematic - North American WM AVR Model (WM 60 BAL AVR TVSS)

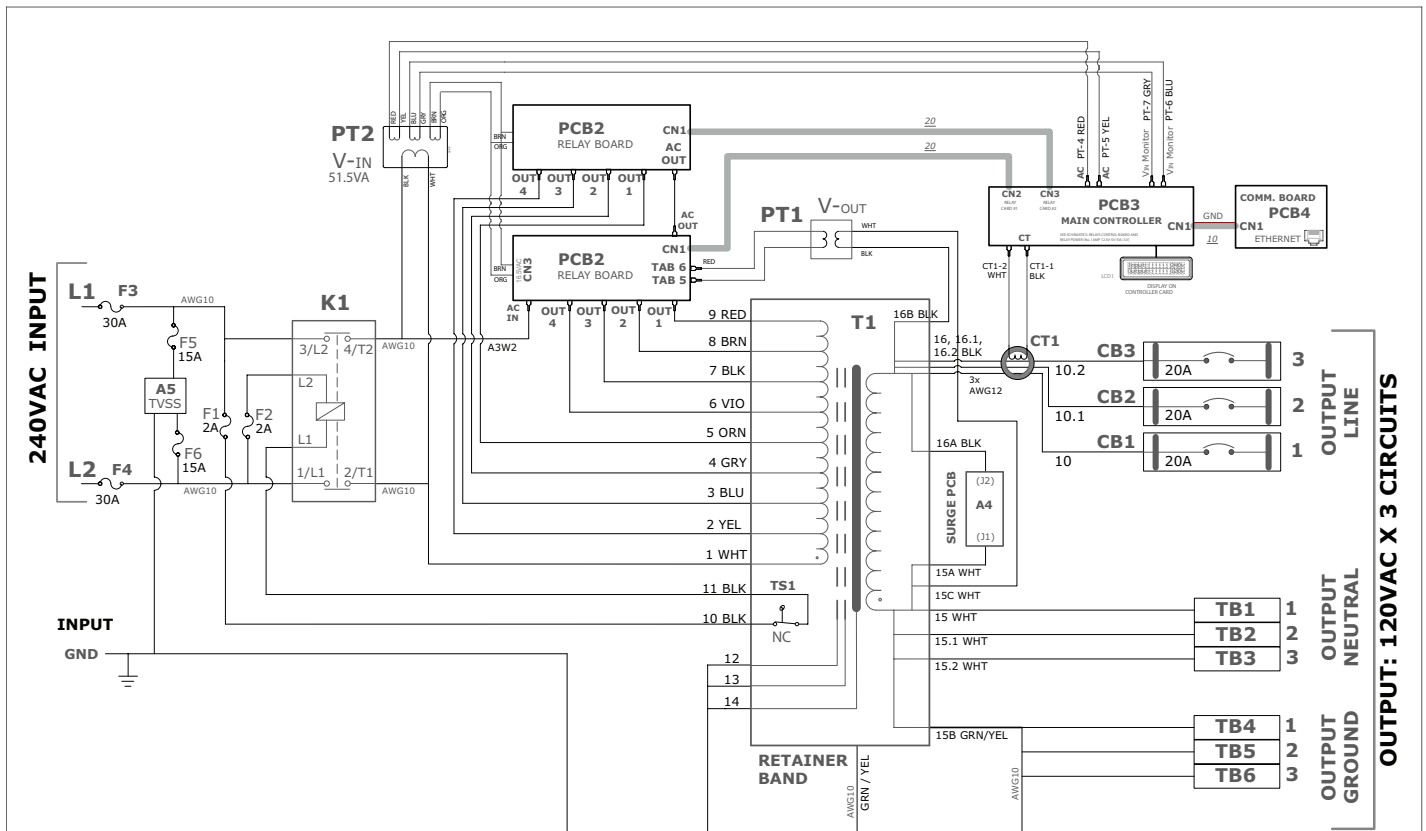

COMPONENT PANEL

- | | |
|---|--|
| CT1 : 10576-X0-00 CURRENT TRANSFORMER; TO MONITOR OUTPUT CURRENT | F3-F4 : FUSE: 30A TD; 600VAC, TYPE J; use: LPJ-30SP or JDL30 in holder JT60030 |
| PT2 : 11937-X0-00 POTENTIAL TRANSFORMER; TO MONITOR INPUT VOLTAGE AND SUPPLY POWER TO PCB3 AND PCB5 | F1-F2 : FUSE: 2.0A FA; 250VAC, 20mm X 5mm @ 250V |
| PT1 : 10575-X0-02 POTENTIAL TRANSFORMER; TO MONITOR OUTPUT VOLTAGE | F5-F6 : FUSE: 15A FA; 250VAC, 31.75mm X 6.35mm |
| T1 : 11134-V1-02 MAIN POWER TRANSFORMER 7.08kVA | K1 : 2-POLE CONTACTOR, 30A, 600VAC, COIL: 208-240VAC |
| PCB1 : 580240 - 9 AVR RELAY BOARD | A4 : SURGE SUPPRESSOR ACROSS THE OUTPUT |
| PCB2 : 580240 - 9 AVR RELAY BOARD | A5 : EMERSON POWERSURE LOW EXPOSURE SURGE SUPPRESSOR |
| PCB3 : CONTROLLER PCB; DISPLAY I/O VOLTAGE AND CURRENT | CB1-CB3 : THREE OUTPUT LINE CIRCUIT BREAKERS, 20A EACH |
| PCB4 : COMM. PCB; RJ45 NETWORK, RS-232, 12V TRIGGER AND 12V FAULT | TB1-TB3 : OUTPUT NEUTRAL TERMINAL BLOCK |
| TS1 : TRANSFORMER TEMPERATURE LIMIT SWITCH 130°C, NORMALLY CLOSED | TB4-TB6 : OUTPUT GROUND TERMINAL BLOCK |
| | TB1-TB6 : AWG 16 to 6, TORQUE: 2.0Nm/18 lb-in |

CUSTOMER WIRING CONNECTIONS

INPUT MAINS SUPPLY: L1, L2 INPUT GROUND

OUTPUT TO LOAD / EQUIPMENT: CB1,TB1. CB2,TB2. CB3,TB3. OUTPUT GROUND TB4 - TB6

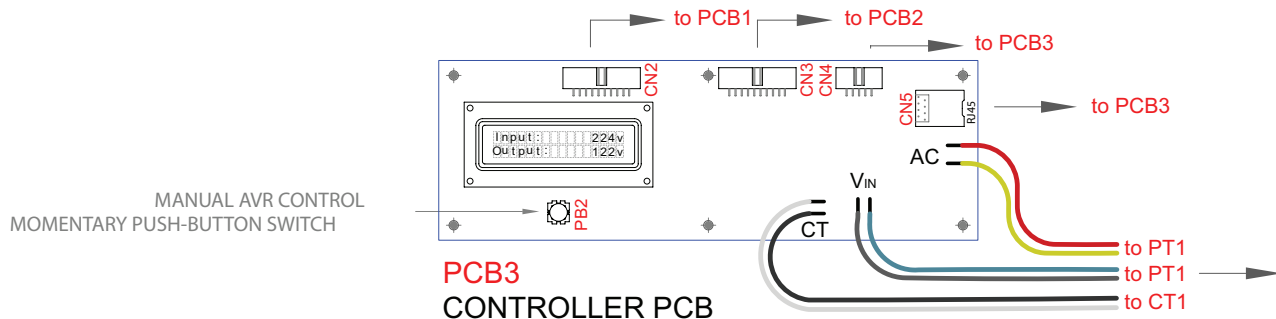

Note:

Circuit schematic drawing is provided for reference only, Torus Power WM AVR units have no user serviceable parts inside. Please return unit to manufacturer for repair and service when required.

Layout - North American WM AVR Model (WM 60 BAL AVR TVSS)

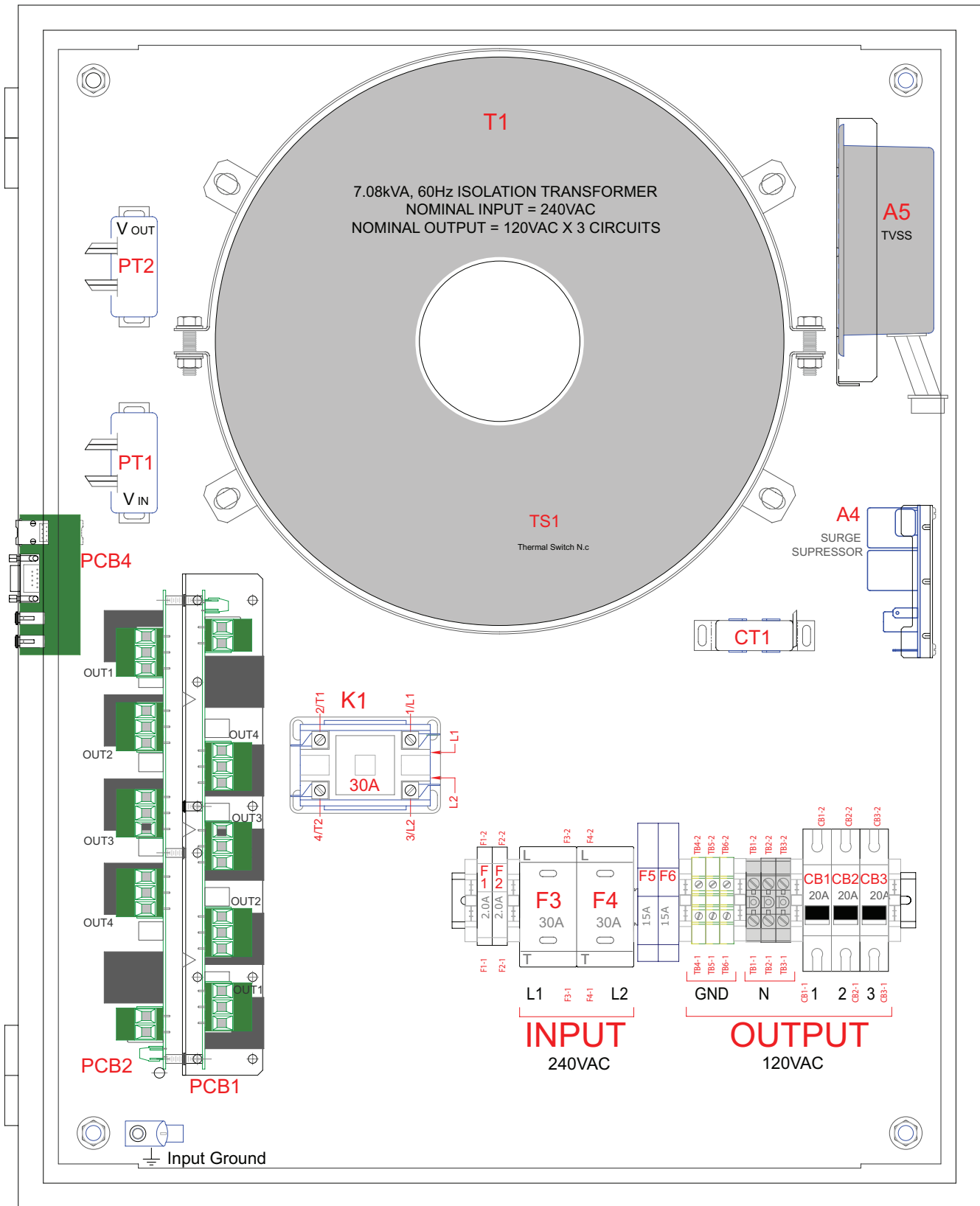

Note:

Layout drawing is provided for reference only, Torus Power WM AVR units have no user serviceable parts inside. Please return unit to manufacturer for repair and service when required.

Electrical Specifications - North American Models

Model Number	Input Voltage Nominal	Output Voltage Nominal	Surge Suppression	Input Current Limiting	Output Circuit Breakers	Maximum Available Output Current
WM 45 BAL AVR	240VAC, 60Hz (Operating Range 170V to 270V)	120VAC ±5V	NO	2x25A (Fuses)	3x20A	45A
WM 60 BAL AVR				2x30A (Fuses)	3x20A	60A
WM 75 BAL AVR				2x40A (Fuses)	5x20A	75A
WM 90 BAL AVR				2x45A (Fuses)	5x20A	90A
WM 45 BAL AVR TVSS	240VAC, 60Hz (Operating Range 170V to 270V)	120VAC ±5V	YES	2x25A (Fuses)	3x20A	45A
WM 60 BAL AVR TVSS				2x30A (Fuses)	3x20A	60A
WM 75 BAL AVR TVSS				2x40A (Fuses)	5x20A	75A
WM 90 BAL AVR TVSS				2x45A (Fuses)	5x20A	90A

Electrical Specifications - International Models

Model Number	Input Voltage Nominal	Output Voltage Nominal	Surge Suppression	Input Current Limiting	Output Circuit Breakers	Maximum Available Output Current
WM 30 AVR	240VAC, 50/60Hz (Operating Range 170V to 270V)	220-240VAC ±10V	NO	2x30A (Fuses)	3x15A	30A
WM 45 AVR				2x45A (Fuses)	5x15A	45A
WM 30 AVR TVSS	240VAC, 50/60Hz (Operating Range 170V to 270V)	220-240VAC ±10V	YES	2x30A (Fuses)	3x15A	30A
WM 45 AVR TVSS				2x45A (Fuses)	5x15A	45A

Mechanical Specifications - North American Models

Model Number	Weight KG(lb)	Size, mm (HxWxD) Size, inch (HxWxD)	Construction
WM 45 BAL AVR	79.5 (175)	826x627x261 32.5x24.7x10.3	NEMA TYPE 1 Enclosure 14 guage steel Black Powder Coat Slip hinges enable door removal 1/4 turn latch
WM 60 BAL AVR	91.5 (202)		
WM 75 BAL AVR	103.5 (228)		
WM 90 BAL AVR	105.5 (233)		
WM 45 BAL AVR TVSS	81(179)	826x627x261 32.5x24.7x10.3	
WM 60 BAL AVR TVSS	93(205)		
WM 75 BAL AVR TVSS	105(232)		
WM 90 BAL AVR TVSS	107(236)		

Mechanical Specifications - International Models

Model Number	Weight KG(lb)	Size, mm (HxWxD) Size, inch (HxWxD)	Construction
WM 30 AVR	102.5 (226)	826x627x261 32.5x24.7x10.3	NEMA TYPE 1 Enclosure 14 guage steel Black Powder Coat Slip hinges enable door removal 1/4 turn latch
WM 45 AVR	112.5 (248)		
WM 30 AVR TVSS	104(229)	826x627x261 32.5x24.7x10.3	
WM 45 AVR TVSS	114(251)		

Wall Cabinet External Layout - WM AVR Series

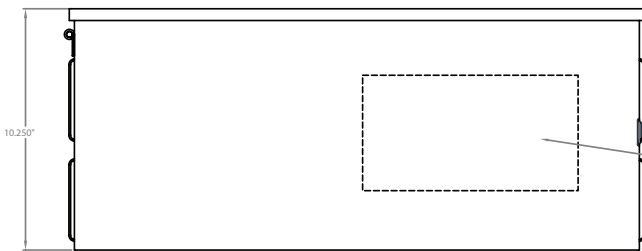
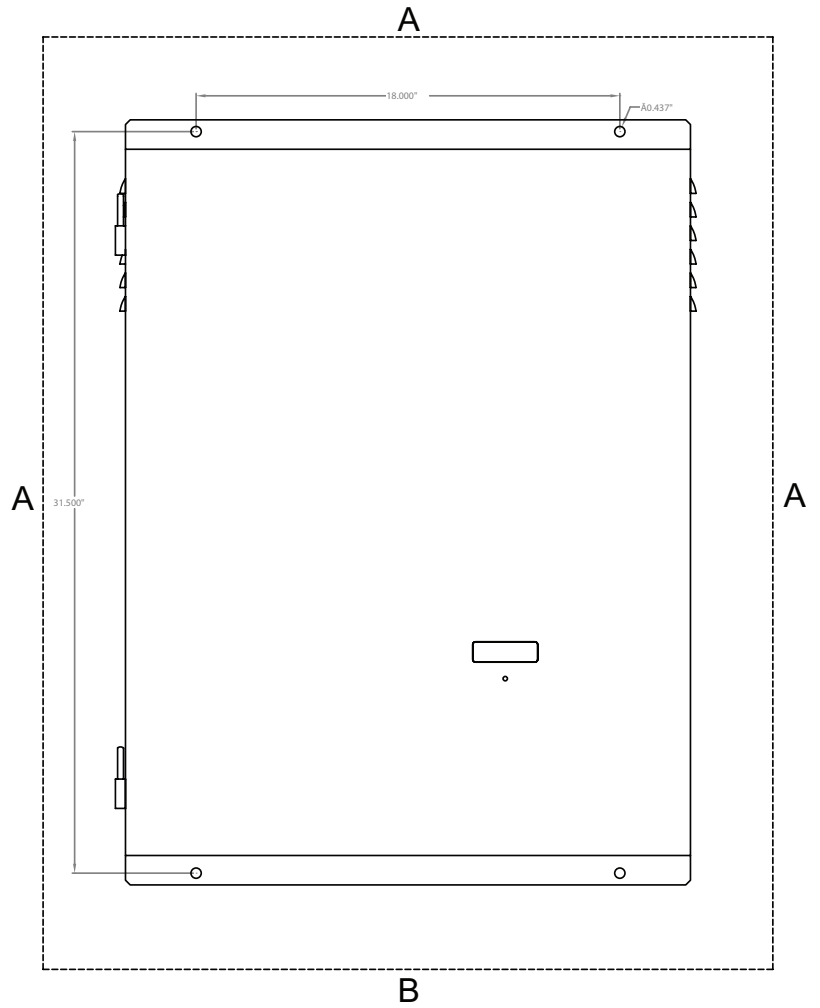
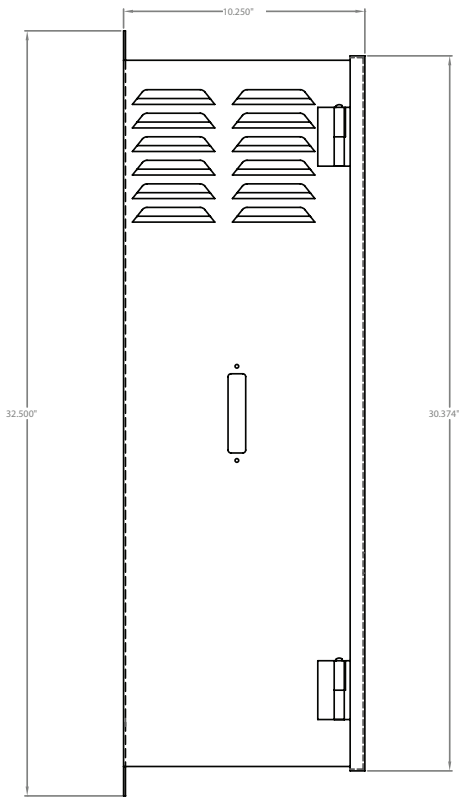

Space around unit as shown above:
 'A' = 5.00"
 'B' = 6.00"

Customer electrical connections:
 Wiring conduit holes should be added as required to this area.

Home Automation Interface through RS232

Serial Port Settings

9600 baud

8 data bits

No parity

Commands are terminated with the carriage return character (13 decimal).

Command	Description	Response
"C0<CR>"	Turn power OFF	"OK<CR>"
"C1<CR>"	Turn power ON	"OK<CR>"
Other Commands	Not supported	"ERROR<CR>"

Warranty

Torus Power Inc. products are warranted to be free from manufacturing defects as follows:

- Five years from the original date of sale for toroidal transformers
- Two years from the original date of sale for all other components

The product warranty includes parts, labour and return shipping to the customer. Shipping to Torus Power Inc. for warranty repair is the responsibility of the customer.

Warranty coverage is not transferrable and original proof of purchase is required for warranty claims.

In the event of a warranty claim, Torus Power Inc. will remedy the issue by repair or replacement, as we deem necessary, to restore the product to full performance.

This warranty is considered void if the failure of the product or any component part is caused by damage or misuse.

Failure to fully comply with Torus Power operating instructions voids the warranty.

Torus Power products are marketed worldwide by Torus Power Inc.

For sales contact:

sales@toruspower.com

Phone: (+1) 416-477-4799

Toll free: 1-877-337-9480

Technical inquiries:

tech@toruspower.com

Phone: (+1) 416-477-4799

Toll free: 1-877-337-9480



TORUS POWER

Engineered to perform
& protect like no other

**Toroidal Isolation
Power Transformers**

Torus Power Inc.

2861 Sherwood Heights Drive

Suite 26

Oakville, ON L6J 7K1

www.toruspower.com