



**TORUS  
POWER™**

**Isolate.**

**Protect.**

**Inspire!**

# AVR Manual

**Audio / Video Power Isolation Units  
with Automatic Voltage Regulation**

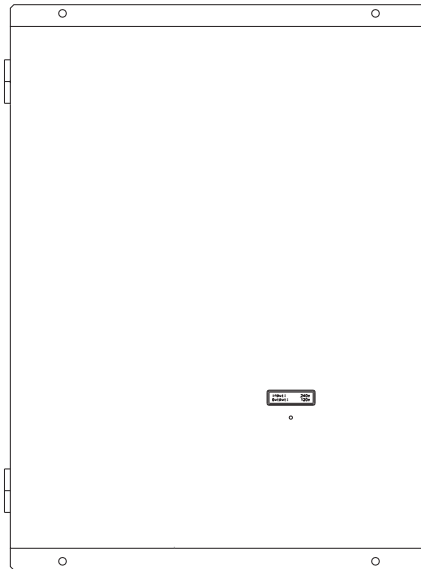

<b>Model Number</b>	Description	Input Voltage	Input Current	Output Voltage	Output Current
<b>WM 75 BAL AVR</b>	Balanced 75A	Nominal 240V	37.5A	4x120V	4x20A

**Warning:**

**User is responsible for installing this unit in accordance with all local, provincial/state and federal electrical code requirements. The installation of this unit requires inspection and approval by local electrical safety authority. This wall mount unit is not equipped with a power safety interlock.**

# Table of Contents

---

<b>Table of Contents</b> .....	<b>Page 1</b>
<b>Important Safety Instructions</b> .....	<b>Page 2</b>
<b>Shipping Carton &amp; Packing Material</b> .....	<b>Page 2</b>
<b>Torus Power AVR Series Power Conditioners - User Notes and Manual</b> .....	<b>Page 3</b>
<b>Front Panel Display</b> .....	<b>Page 4</b>
<b>Interface Connections and AVR Software</b> .....	<b>Page 5</b>
<b>AVR Software - Menu Selection</b> .....	<b>Page 6,7,8</b>
<b>Block Diagram - AVR System</b> .....	<b>Page 9</b>
<b>Layout</b> .....	<b>Page 9</b>
<b>Interior Detail</b> .....	<b>Page 10</b>
<b>Electrical Specifications</b> .....	<b>Page 10</b>
<b>Schematic</b> .....	<b>Page 11</b>
<b>External Layout</b> .....	<b>Page 12</b>
<b>Mechanical Specifications</b> .....	<b>Page 12</b>
<b>Home Automation Interface</b> .....	<b>Page 13</b>
<b>Warranty</b> .....	<b>Page 13</b>



## Important Safety Instructions

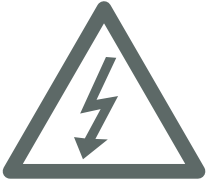

**CAUTION!** To reduce the risk of electric shock and fire, do not remove the cover of this device. There are no user serviceable parts inside. Please refer all servicing to licensed service technicians.

**CAUTION!** The international symbol of a lightning bolt inside a triangle is intended to alert the user to uninsulated "dangerous voltage" within the device's enclosure. The international symbol of an exclamation point inside a triangle is intended to alert the user to the presence of important operating, maintenance and servicing information in the manual accompanying the device.

**CAUTION!** To prevent electrical shock, match wide blade of plug to wide slot, fully insert.

**CAUTION!** To reduce the risk of electrical shock, do not expose this equipment to rain or moisture.

**CAUTION!** To reduce the risk of electrical shock, ensure the fuses are replaced with the appropriate fuse according to the unit markings.



1. Read Instructions—All safety and operating instructions should be read before operating the device.
2. Retain Instructions—The safety and operating instructions should be retained for future reference.
3. Heed Warnings—All warnings on the device and in the operating instructions should be adhered to.
4. Follow Instructions—All operating and safety instructions should be followed.
5. Water & Moisture—The device should never be used in, on or near water for risk of fatal shock.
6. Ventilation—The device should always be located in such a way that it maintains proper ventilation. It should never be placed in a built-in installation or anywhere that may impede the flow of air through its ventilation slots.
7. Heat—Never locate the device near heat sources such as radiators, floor registers, stoves or other heat-generating devices.
8. Dangerous Entry—Care should be taken that no foreign objects or liquids fall or are spilled inside the device.

9. Damage Requiring Service—The device should be serviced by licensed technicians when:

- Objects have fallen or liquid has spilled inside the device.
- The device has been exposed to moisture.
- The device does not appear to be operating properly or exhibits a marked change in performance.
- The device has been dropped or the enclosure becomes damaged.

10. Service—The device should always be serviced by licensed technicians. Only replacement parts specified by the manufacturer should be used. The use of unauthorized substitutions may result in fire, shock, or other hazards.

11. If the equipment is used in a manner not specified by the manufacturer, the protection provided by the equipment may be impaired.

12. **CAUTION** Units in this series are heavier than 55 kg (121.2 lb). Use safe practices when lifting.



≥18 kg (39.7 lb)

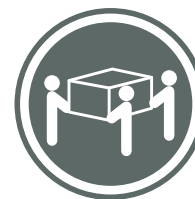

≥32 kg (70.5 lb)



≥55 kg (121.2 lb)

## Shipping Carton & Packing Material

Please keep the original shipping box and all packing material. This will ensure the AVR is protected in future transport.

In the unlikely event you have a problem and must return it for service you must use the proper packing material.

Ship the AVR only in the original packing material, as the unit is not insurable by carriers otherwise.



### Placement and ventilation

Allow 1" distance on all sides when positioning the AVR for proper ventilation, and allow 6" behind the AVR for adequate wiring space. Do not place heat-generating devices directly below the AVR.

### Connecting components and using the AVR

Using the AVR is as simple as plugging in audio and video components to the outlets on the rear panel. The order and position in which you connect your components will not affect the performance of the AVR or your components. Connect the AVR to the wall outlet, and switch it on. Turn on the components individually.

While the AVR has built-in software that can be accessed via the Ethernet connection, there is no need for you to use this software. The AVR system provides all the standard features, performance, and benefits out of the box by simply plugging it in as described in this section. You can use the AVR software to monitor the voltage conditions via your computer, and for such additional features as being able to turn your system on/off remotely and change the duration of display

### Torus AVR – Description

Torus Power AVR (Automatic Voltage Regulation) is a full-feature state-of-the-art power conditioner, isolating and protecting your system. Like all Torus Power products, the AVR series provides true isolation (using massive toroidal transformers) and protects all connected equipment from the risk of severe power line surges using series-mode surge suppression. In addition, Torus AVR provides stable voltage to keep equipment running in the optimal range of 115VAC to 125VAC for any input voltage from 85V to 135VAC for 120V input and 170V to 270VAC for Balanced 240V input.

Torus Power AVR series uses a micro-processor to monitor and control the power provided to connected components. The front panel display on the Torus Power AVR indicates input and output voltages, and displays output current, as well as displaying fault conditions.

The Torus Power AVR is pre-programmed to power down the system when a high or low fault conditions occurs (user can over-ride).

There are multiple interfaces built into the Torus Power AVR:

- 1) Ethernet interface with built-in web browser allows any computer to view voltage and current readings and turn the AVR unit on or off.
- 2) RS-232 is provided for connection to media control systems.
- 3) Two 12V triggers are provided.

### Does your system need automatic voltage regulation?

Under ideal conditions, when the supplied power line is stable and dependable, you may not need voltage regulation. In such an ideal situation, your equipment can operate within the normal tolerance of the line voltage.

In reality, the power supplied to most areas is less than ideal due to outdated power grids. In most areas, the power regularly drops or rises above the acceptable range (in North America  $\pm 5V$ , Europe/Asia/Australia  $\pm 10V$ ). These voltage sags, brownouts, and surges can stress components and shorten equipment life. In the worst case, catastrophic events can destroy valuable equipment. In such real-world conditions, Torus Power AVR can protect your equipment, and improve the quality and enjoyment of your audio and video experience.



## Front Panel Display

---

### Front Panel

The Front Panel display consists of a 2 line LCD and 1 push button.

Typical display.

```
In: 115V
Out: 120V 5.2A
```

Press button to show IP Address.

```
IP Address
10.1.1.112
```

See section on AVR software for further information on the IP Address.

### Voltage Faults

If a high or low voltage condition exists for 30 seconds or more, a voltage fault is displayed and the fault output is turned on and the system shuts down (unless over-ridden by the user).

Display will show

```
System OFF
LOW AC VOLTAGE
```

Or

```
System OFF
HIGH AC VOLTAGE
```

As the output power from the Torus Power AVR is shut down, all the connected equipment is turned off. The AVR power switch remains in the ON position, although there is no power to the load.

The connected equipment should be switched off.

When the voltage has been restored to the normal operating range, the following procedure can be followed:

- The Torus Power AVR can be switched OFF and then ON.
- Wait thirty seconds to verify the fault condition no longer exists.
- The connected equipment should be switched on individually.

If the fault condition still exists, the AVR will require approximately 15 seconds to monitor the incoming voltage, and the system will shut down again.

The user can program the AVR software to allow the system to remain on in case of fault (see AVR software section for details).



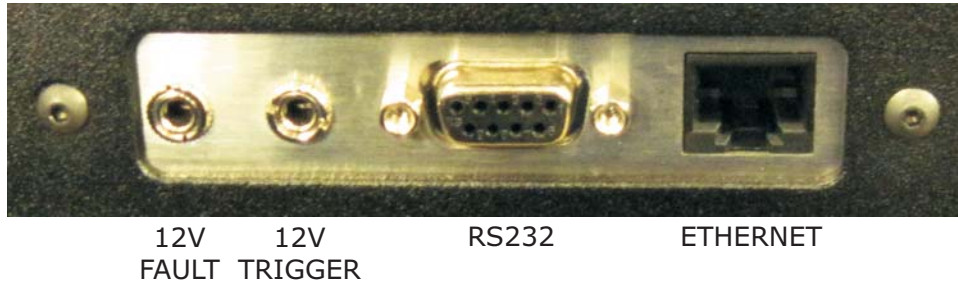

Figure 1: AVR Rear Panel connections.

### Ethernet

Allows access to the AVR and internal software. See AVR Software section for more details.

### RS232

Allows access to automation and external control. See Home Automation Interface commands at end of manual.

### 12V Trigger On/Off

The AVR can be turned on and off by a 12 volt trigger input. Applying 12 volts turns on the AVR and removing the 12 volts turns it off.

### 12V Fault Output

The AVR provides a 12 volt fault output through a jack on the side panel. The output goes to 12 volts when a relay or voltage fault is detected. The maximum current that can be drawn from this output is 75mA.

## AVR Software

AVR software is resident in the microprocessor on the internal control board. There are two methods to access the software.

- 1) Connect the AVR to the Ethernet port. Open a browser window on a PC that is connected to the same network through another Ethernet port. Enter AVR (or the I.P address displayed on the LCD) into the browser window. Press ENTER and the software will open.
- 2) Use a three way Hub, which is connected to an existing network. You then connect both PC and AVR to the same Hub. Open a browser window from the PC. Type AVR, (or the I.P address displayed on the LCD) into the browser window. Press ENTER and the software will open.

### Username and Password

The password is required to change the setup of the Torus unit.

Username is **admin** This is factory set and cannot be changed

Password is **avr** This is the default password, and can be changed.

***In case you forget your password***, the AVR can be restored to the factory default password **avr** by pressing and holding the button on the front panel for at least 10 seconds.



# AVR Software - Menu Selections

## AVR Menu Selections

- AVR Status
- Switch Power
- Setup
- Email Configuration
- Set Password
- Torus Power Home (website)
- Network configuration

Below is a screen by screen description of software options.

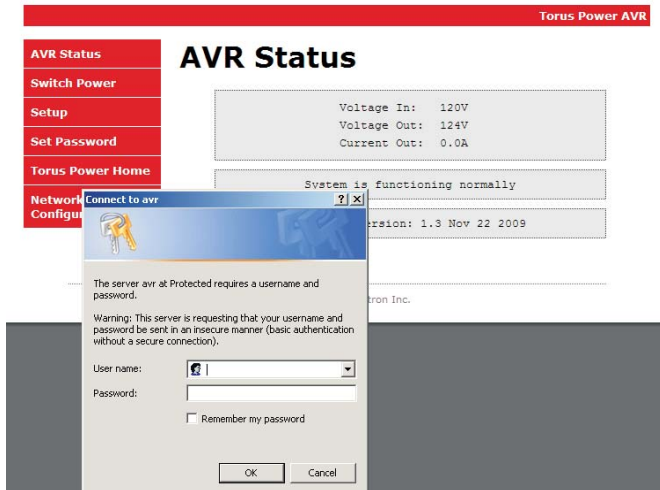

To access AVR software, enter user name and password.

User name :

**admin**

is factory set and cannot be changed

Default Password :

**avr**

You can change your password.

Select **Set Password**  
**AVR Status**

This screen indicates the overall status of the system, showing Voltage In, Voltage Out, and Current output.

It also reports if the system is functioning normally or whether there is a fault condition.

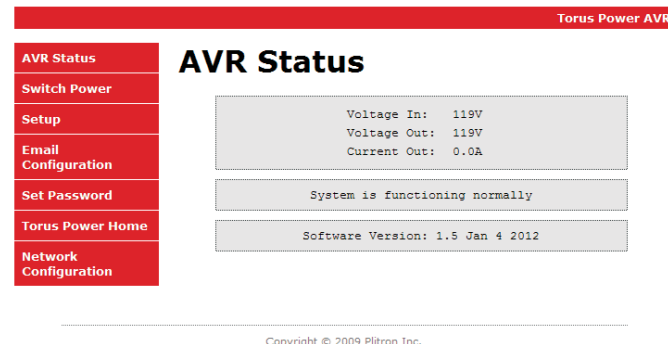

## AVR Power Control

This screen allows ON or OFF control of the AVR unit.

Press **SET** button to implement your selection.

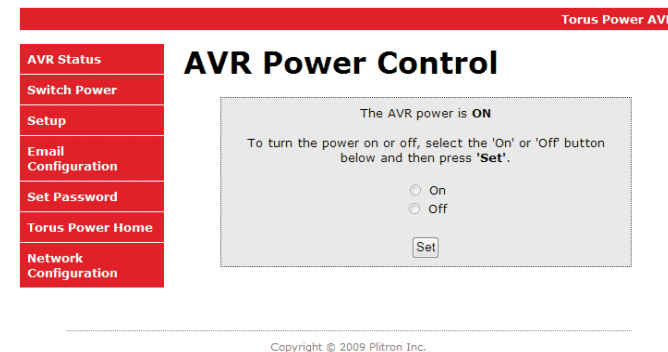

**AVR Setup**

This page allows the configuration of the AVR's programmable parameters.

Shutdown on Low or High line voltage

LCD Backlight Always On

LCD Backlight Time:  (0 to 255 seconds)

Copyright © 2009 Plitron Inc.

### AVR Setup

This screen allows the user to configure two AVR parameters.

**1. Shutdown on Low or High line voltage.** (The factory default is YES – to shut down in case of fault conditions.) Unselecting this button will override, and the AVR will remain on even if voltage drops or rises beyond the acceptable range.

**2. LCD Display.** Always ON is the default setting. If you don't want the display on all the time, you can select a time from 0 to 255 seconds. When you have made your selections, press **SAVE SETUP**.

### Email Fault Alert Notification

In the unlikely event your AVR experiences an issue the AVR will shut down and send an email notification if this section is configured. After entering the configuration parameters use the 'Send Test Email' button to confirm your settings are correct.

**Email Configuration**

1. Please enter the "Email Address" that the logged data should be sent to.  
2. If you have multiple AVR devices, assign different "Email Subjects" to them to tell apart the logs of different devices.

Email Configuration

SMTP Server:  Port:

User Name:

Password:

Email Address:

Email Subject:

Copyright © 2009 Plitron Inc.

### Set Password

If you wish to change the password, use this screen.

***In case your forget your new password,*** you can restore the AVR to factory default password by pressing the button on the front of the AVR unit and **HOLDING** it down for at least 10 seconds. The default password is **avr**

**Set Password**

Enter New Password:

Re-enter Password:

Copyright © 2009 Plitron Inc.





**Torus Power AVR**

**AVR Network Configuration**

This page allows the configuration of the AVR's network settings.

**CAUTION:** Incorrect settings may cause the AVR to lose network connectivity. Recovery options will be provided on the next page.

Enter the new settings for the AVR below:

MAC Address: 00:50:C2:B5:D0:1A  
Host Name: AVR

Enable DHCP

IP Address: 192.168.1.100  
Gateway: 192.168.1.1  
Subnet Mask: 255.255.255.0  
Primary DNS: 192.168.1.1  
Secondary DNS: 0.0.0.0

Save Config

Copyright © 2009 Plitron Inc.

Each AVR unit has a unique MAC Address which is factory assigned.

The IP address assigned to the AVR is dynamically assigned and is displayed on this screen as well as on the front panel LCD of the AVR.

The AVR can be programmed through the web browser to automatically get an IP address from the network switch or router and this is the default setting and should work on most networks. Some networks require each PC or device to use a fixed IP address and the AVR also supports this option.

### Notes:

1. The output current (Amps) displayed on the LCD is the RMS reading of the load. It does not indicate the peak current loads.
2. There is a 20-second delay built into the AVR system, to prevent nuisance switching. The AVR will take approximately 20-seconds to change relay taps to switch to the proper output voltage setting.
3. Torus AVR will keep the output constant within the range of 115Volts to 125Volts, with an input voltage of 170V to 270V.
4. A drop in the Input voltage is normal when increasing the load on the Torus AVR. This is a result of the impedance of the power line, and is a function of the distance from the electrical panel.

### Switch On Delay Feature

The Automatic Voltage Regulation (AVR) feature is designed to handle normal utility fluctuations to provide the connected equipment with an optimal voltage supply. It is common when utility power is restored after a blackout that the voltage supply is unstable for a few seconds. To further protect connected equipment your AVR is equipped with a start up delay feature. When the power switch is turned on or when the power switch is on and utility power is restored, power will not be connected to the output receptacles until the delay time has passed.



# Block Diagram - AVR System

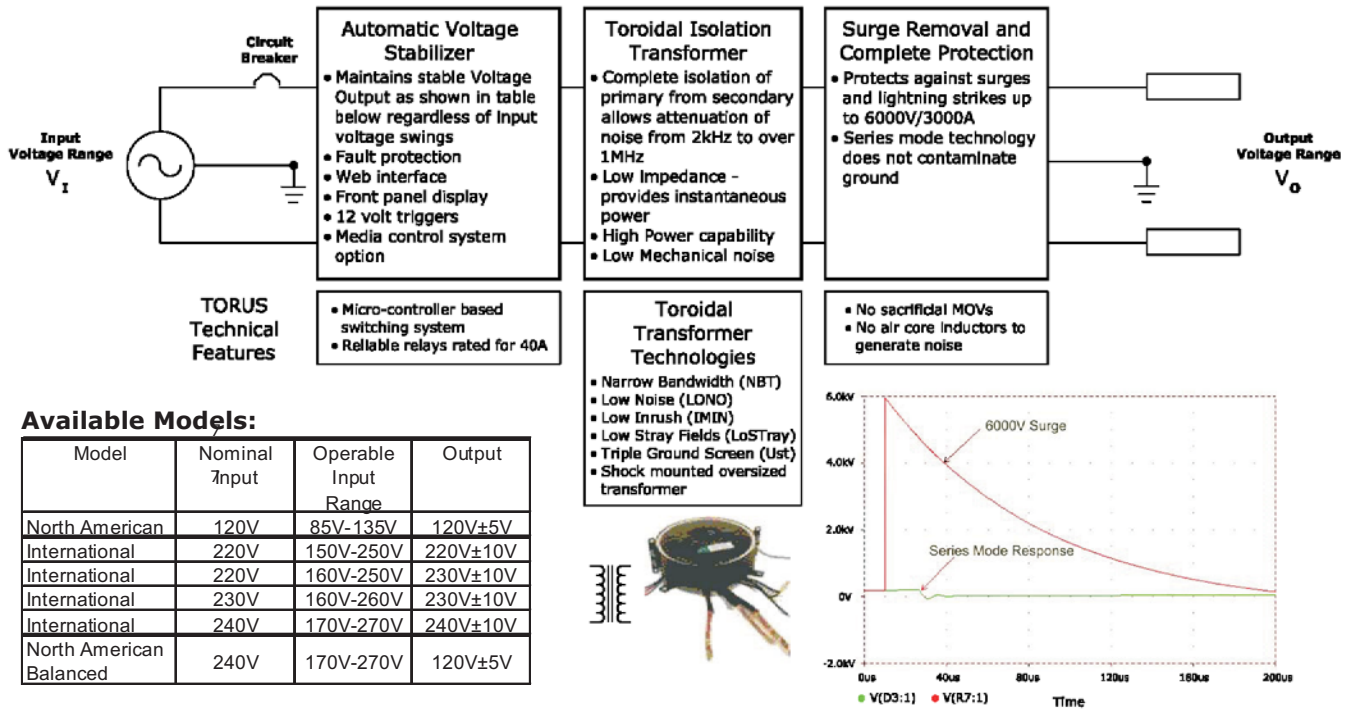

# Layout

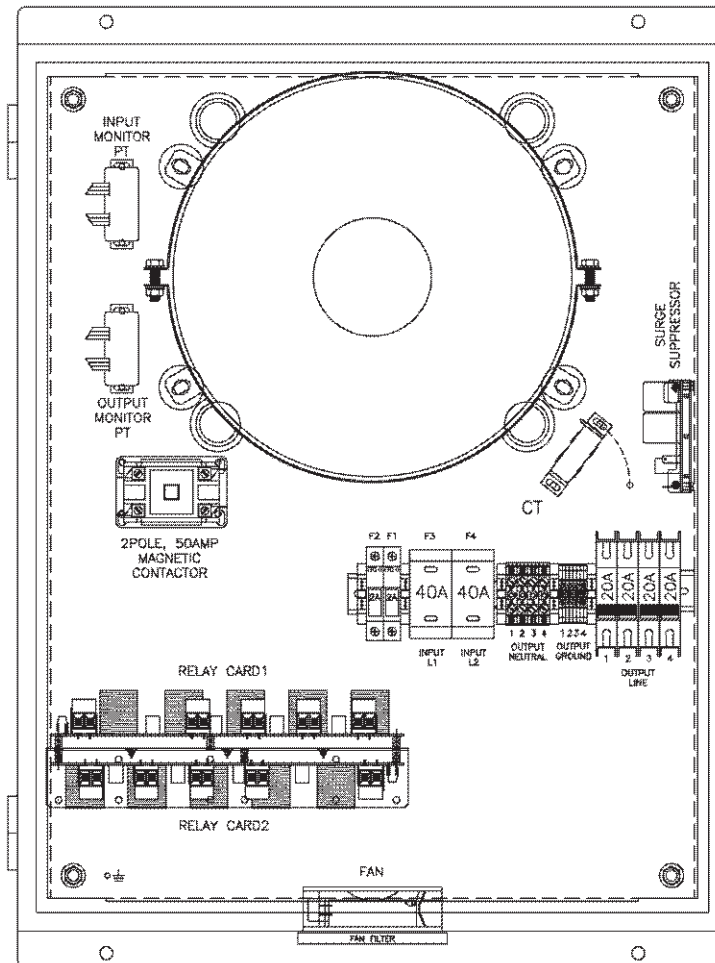

## Interior Detail

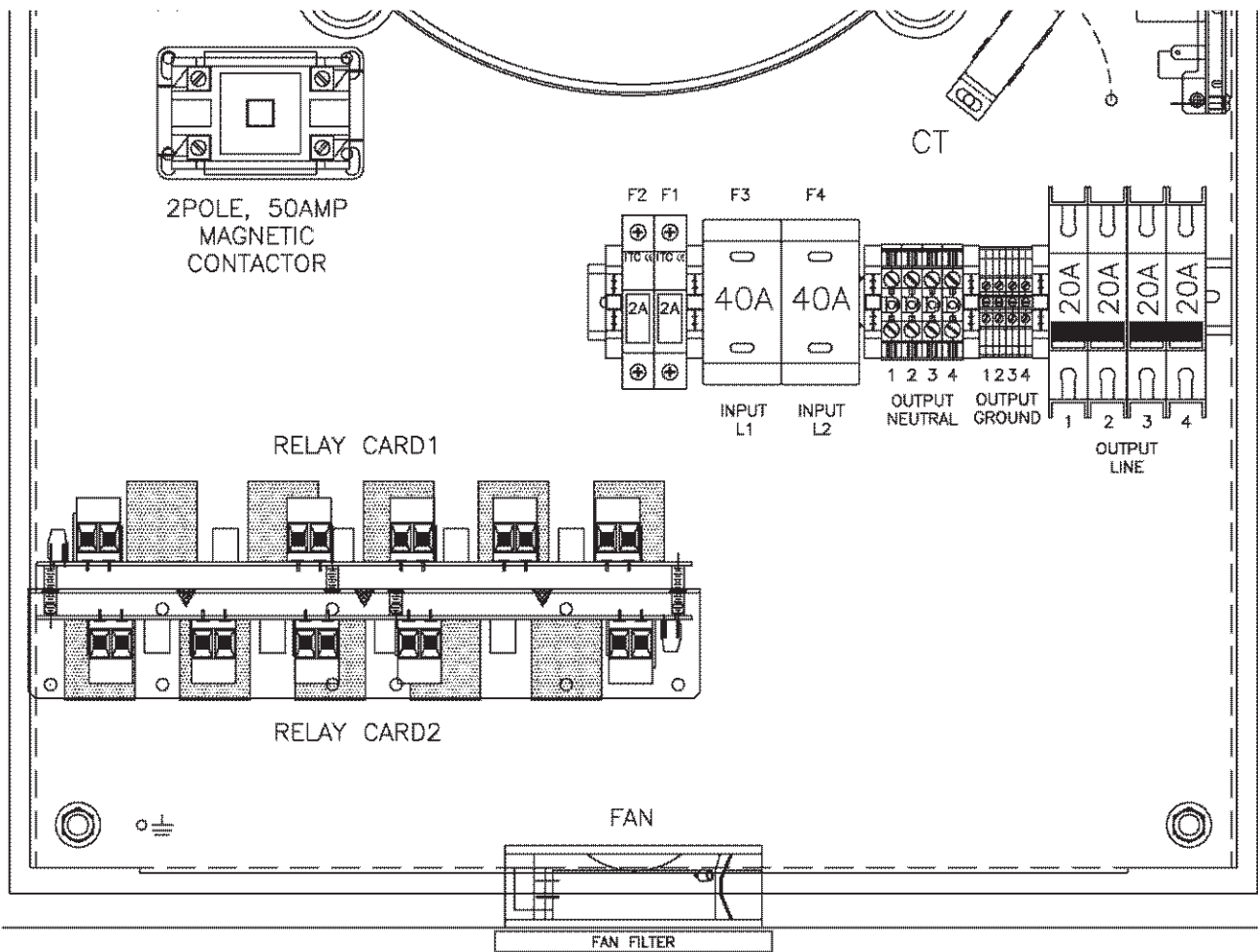

## Thermal Protection

Torus PIUs will shut-down if internal unit temperature reaches excessive levels.

Cabinet Wall-mount PIUs also use forced-air cooling as necessary. A thermal switch activates the fan as required.

## Warning

**Installation by qualified electrician required.**

These units are designed for fixed, hard-wiring of input and output. Installation and wiring of these units, or any household or facility wiring, should be performed by a licenced electrician to local codes. The final installation should also be inspected and passed by a qualified electrical inspector prior to use.

## Electrical Specifications

Model Number	Input Voltage Nominal	Output Voltage Nominal	Input Current	Output Rating	Load Regulation	Over-current Protection
WM 75 BAL AVR	240VAC 57-63Hz	120VAC	37.5A	4 X 20A Circuit Breakers	1.5%	Input: 40A time-delay fuses (2)



# Schematic

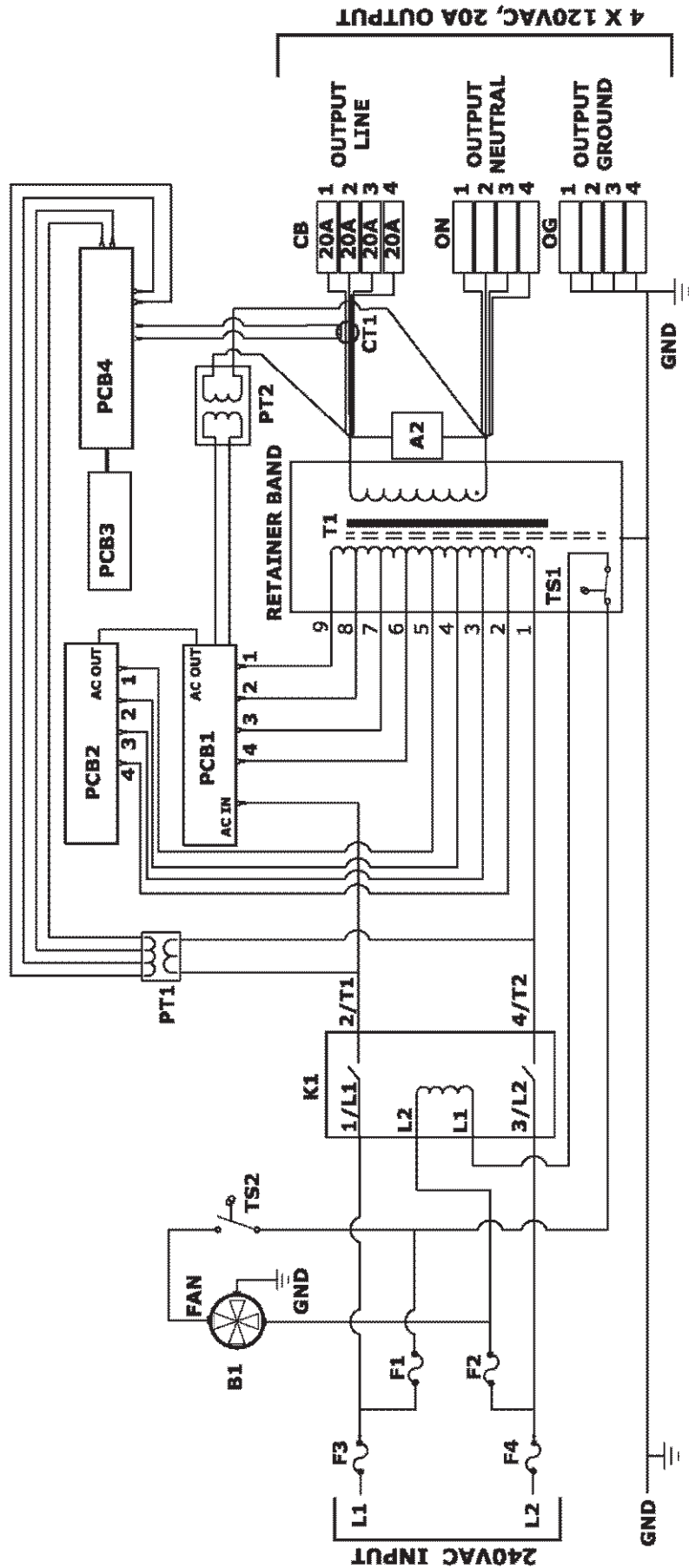

## External Layout

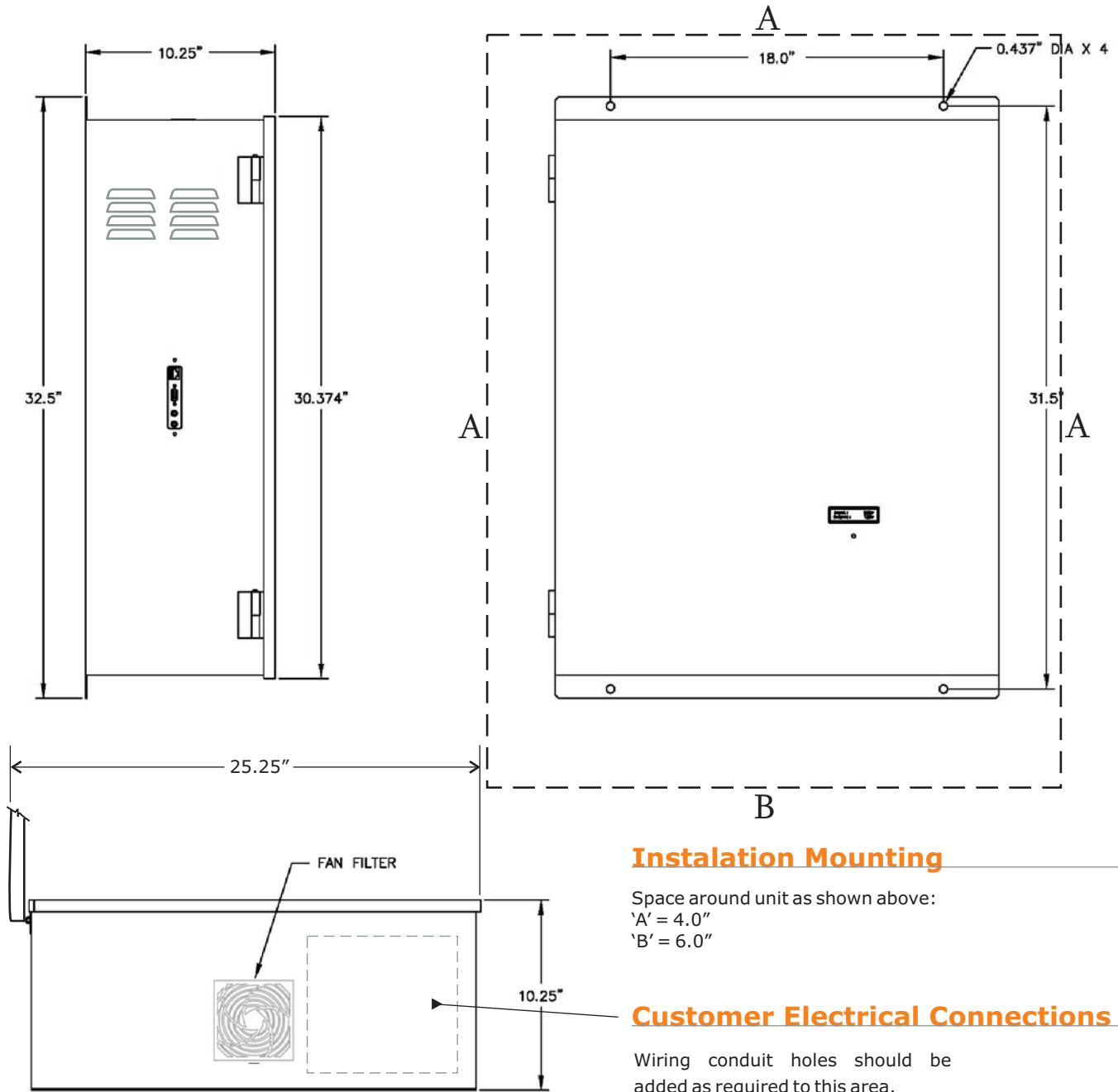

## Mechanical Specifications

Model Number	Construction	Weight	Size (w" x d" x h")
WM 75 BAL AVR	NEMA 1 Enclosure 16 gauge steel Black Powder-Coat Slip hinges enable door removal 1/4 turn latch	198 lbs.	25.25 x 10.25 x 32.5



## Home Automation Interface

---

### Serial Port Settings

9600 baud  
8 data bits  
No parity

Commands are terminated with the carriage return character (13 decimal).

Command	Description	Response
"C0<CR>"	Turn off power	"OK<CR>"
"C1<CR>"	Turn on power	"OK<CR>"
Other commands	Not supported	"ERROR<CR>"

## Warranty

---

Torus Power products are warranted to be free from manufacturing defects for five years from the original date of sale. This includes parts, labour and return shipping to the first registered owner and all subsequent registered owners. Warranty coverage is extended to applicable products registered or having proof-of-purchase (sales invoice, etc.).

In the event of a defect or malfunction, Torus Power will remedy the problem by repair or replacement, as we deem necessary, to restore the product to full performance.

This warranty is considered void if the defect, malfunction or

failure of the product or any component part was caused by damage (not resulting from a defect or malfunction) or abuse while in the possession of the customer. Failure to fully comply with Torus Power operating instructions, voids the warranty.



Torus Power products are marketed worldwide through Plitron Manufacturing Inc.

**For sales contact:**  
**[torussales@plitron.com](mailto:torussales@plitron.com)**  
Phone: 416-667-9914  
Toll free: 1-800-754-8766  
Fax: 416-667-8928

**Technical inquiries:**  
**[torustechnical@plitron.com](mailto:torustechnical@plitron.com)**  
Phone: 416-667-9914



**[www.TorusPower.com](http://www.TorusPower.com)**

Torus Power  
#8 601 Magnetic Drive  
Toronto, ON M3J 3J2  
Canada  
416-667-9914

Specifications subject to change without notice.  
© Torus Power 2012